

**SPOTLIGHT**  
*Architectural*

**All the  
world  
is a stage.**

**The MIDI.range**  
**Experience From The Stage.**



# The MIDI.range

## How to choose the correct MIDI for you

Dedicated architectural lighting fixtures drawing their influence from our years of experience in the Theatrical and Stage Lighting sectors.

### MIDI 150 Fresnel

This flexibility of use, its compact size and its sturdy construction make the MIDI.Fresnel 150W particularly suitable for heavy use such as theatrical or rental applications. The high efficiency long-life Mastercolour lamp (9,000 hours) makes it ideal in situations where prolonged usage is required, along with high light rendering and low running costs. There are several lamp options available giving either a light tone similar to the halogen lamps (MCD 150) or a whiter light and higher rendering (CDM-SA/T).

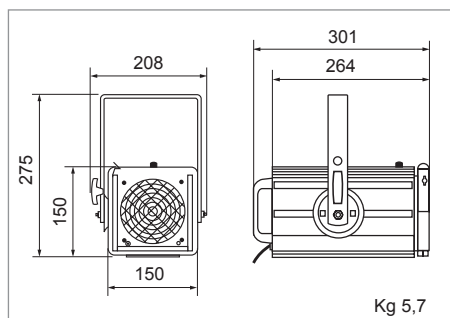
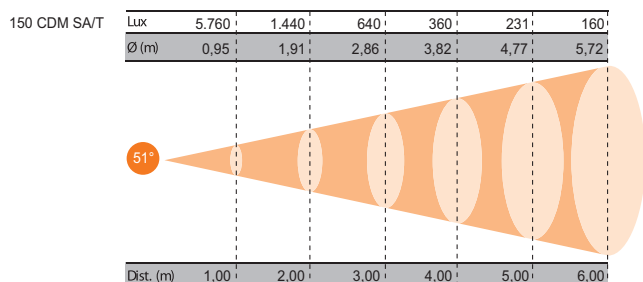
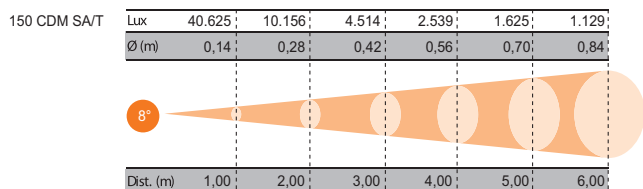

### MIDI 250 Fresnel, PC

The 250W discharge lamp with its high efficiency ceramic burner gives a similar light output to a conventional 1,000W lamp with the power consumption of 250W only, making the fixture an ideal solution where maximum efficiency at the lowest operational costs is required: exhibitions, shopping centres, and public venues. The warm white colour of the Hot-Restrike lamp (3200°K CCT) makes this fixture suitable to be installed together with existing halogen spots in theatres, multi-functional halls, etc. with the extra advantage of a longer life-time. The design of the housing is the same as the Spotlight's SINTESI range, who's optical, electrical and heat dissipation design solutions have made this product successful in the professional theatre market for such a long time. Different versions with Magnetic or Electronic ballast, built-in or external, Cold or Hot re-strike.

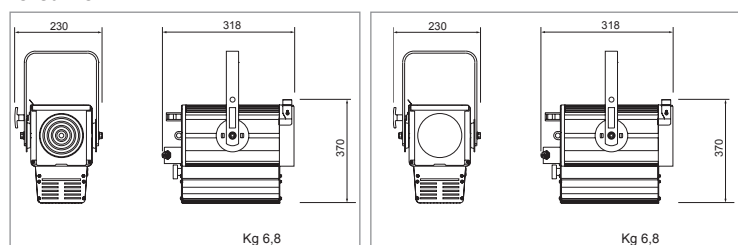

## Fresnel

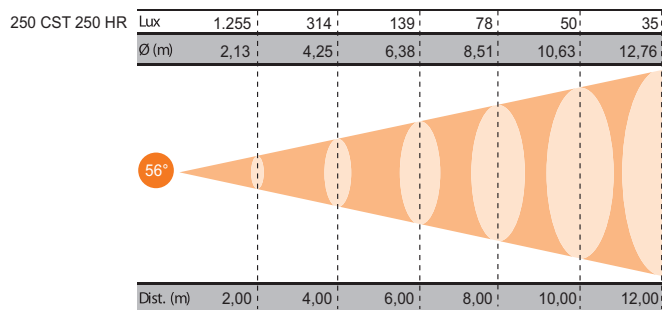
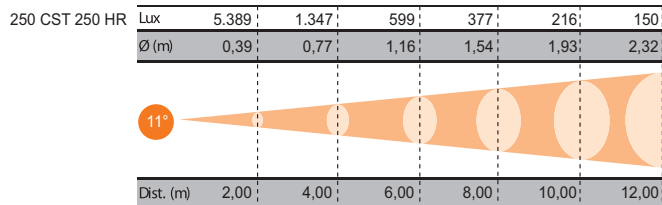

## PC

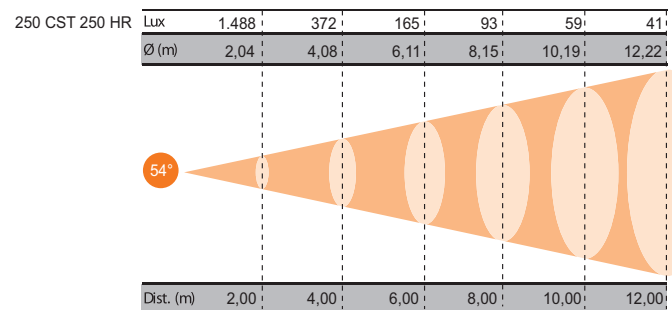
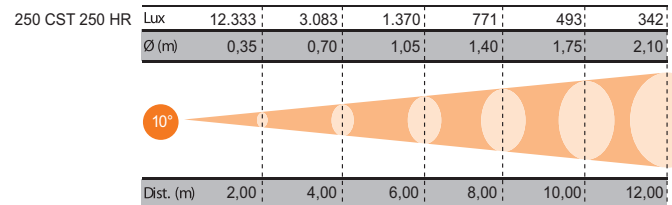

## MIDI 250 Profile

250W zoom Profile spot . Image, pattern and logo projector both in black and white or colour thanks to a wide range of Gobos readily available, in both standard library stock or with custom designs.

Like for the other two products of the family (the MIDI.Fresnel and PC) the 250W discharge lamp gives a similar light output to a conventional 1,000W lamp with the power consumption of 250W only, adding the advantage of a warm white colour (3200°K CCT) of the beam.

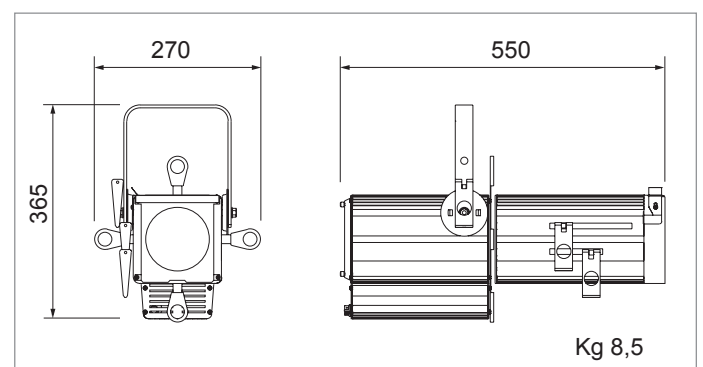
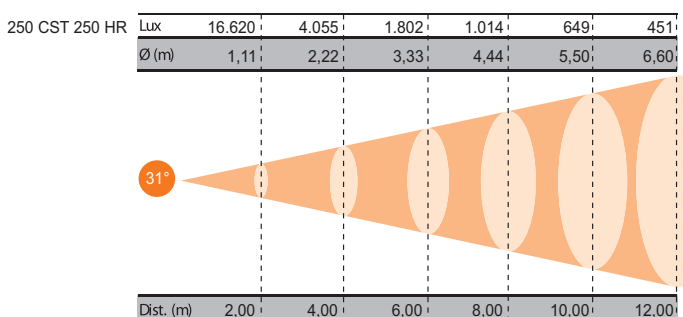
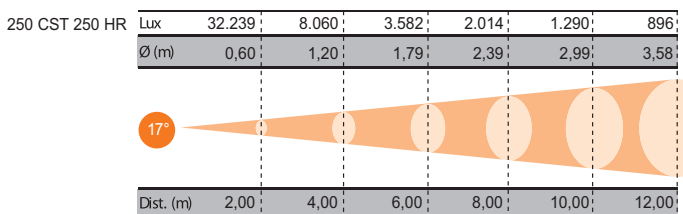

# Versions and Lamps

## MIDI 150 Fresnel: MDFR CDM150 CRM

Codice / Product code	CDM T 150/830	CDM SA/T	CDM TD 150/942
Potenza / Power (W)	150	150	150
Apertura fascio / Beam angle (Degr°)	n.a.	n.a.	n.a.
Base portalampada / Lampholder base	G 12	G 12	G 12
Candele / Candle-power (CD)	14.000	12.900	12.700
Vita media / Avg. rated life (hh)	6.000	9.000	6.000
Temperatura colore / Colour Temperature (°K)	3.000	4.200	4.200
Resa cromatica / Colour rendering index (Ra)	85	96	96
Codice / Product code	HSD 150 W/70	HSD 150 W/UL/75	
Potenza / Power (W)	150	150	-
Apertura fascio / Beam angle (Degr°)	n.a.	n.a.	-
Base portalampada / Lampholder base	G 12	G 12	-
Candele / Candle-power (CD)	12.000	11.000	-
Vita media / Avg. rated life (hh)	3.000	6.000	-
Temperatura colore / Colour Temperature (°K)	7.000	7.000	-
Resa cromatica / Colour rendering index (Ra)	85	85	-

## MIDI 250 Fresnel, PC: MDFR CST250 CRM MDFR CST250 HRE MDFR CDM250/SBA MDFR CDM250 CRM MDPC CST250 CRM MDPC CST250 HRE MDPC CST250/SBA MDPC CDM250 CRM

Codice / Product code	CST 250 HR	MSR 250 HR	
Potenza / Power (W)	250	250	-
Apertura fascio / Beam angle (Degr°)	n.a.	n.a.	-
Base portalampada / Lampholder base	GZY 9.5	GZY 9.5	-
Candele / Candle-power (CD)	22.000	20.000	-
Vita media / Avg. rated life (hh)	4.000	500	-
Temperatura colore / Colour Temperature (°K)	3.200	6.000	-
Resa cromatica / Colour rendering index (Ra)	> 90	> 90	-
Codice / Product code	CDM-T 250W/942	CDM-T 250W/830	
Potenza / Power (W)	250	250	-
Apertura fascio / Beam angle (Degr°)	n.a.	n.a.	-
Base portalampada / Lampholder base	G 12	G 12	-
Candele / Candle-power (CD)	23.300	23.000	-
Vita media / Avg. rated life (hh)	8.000	8.000	-
Temperatura colore / Colour Temperature (°K)	4.200	3.000	-
Resa cromatica / Colour rendering index (Ra)	94	89	-

## MIDI 250 Profile: MDPR CST250 CRM

Codice / Product code	CST 250 FF	MSR GOLD 300 FF	
Potenza / Power (W)	250	300	-
Apertura fascio / Beam angle (Degr°)	n.a.	n.a.	-
Base portalampada / Lampholder base	PGJX 28 (Fast Fit small)	PGJX 28 (Fast Fit small)	-
Candele / Candle-power (CD)	22.000	22.000	-
Vita media / Avg. rated life (hh)	4.000	750	-
Temperatura colore / Colour Temperature (°K)	3.200	8.000	-
Resa cromatica / Colour rendering index (Ra)	> 90	75	-

# SPOTLIGHT

Architettura

Spotlight Srl  
Via Sardegna 3, 20098 - S. Giuliano Milanese, Milano - Italy  
Tel. +39 02 98 83 01 - Fax +39 02 98 83 022  
www.spotlight.it